

SALISBURY SOLAR SPOTLIGHT

USER GUIDE



Ensure your solar panel is South facing or as near as possible



Clean your solar panel from time to time

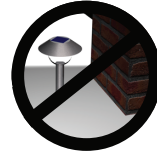

Do NOT place your solar panel in shaded areas.



Do NOT charge behind glass

Thank you for choosing the Salisbury Solar Spotlight. Please read these instructions carefully before using your light.

Important notes

Always take care when installing your light. If you are at all unsure, please contact your retailer or a professional trades person for advice.

Specifications

Solar Panel: 5V, 3W
Li-ion battery: 3.7V 3000mAh
Induction angle: 360°
Induction distance: 4-6M
Product size: 24x17.5x37cm

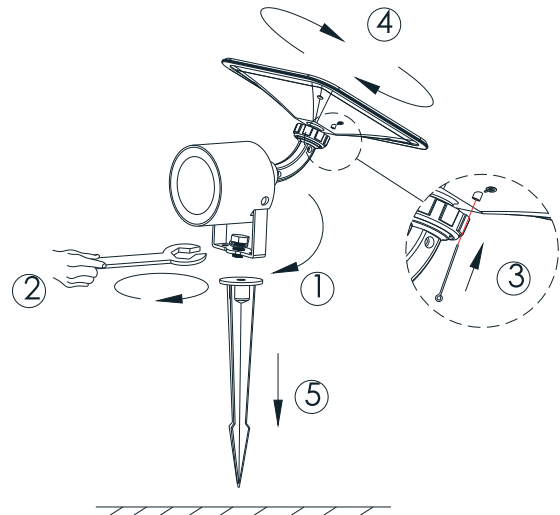

Installation

Remove all packaging and put to one side. Please carefully consider where you wish to install your light before making alterations to your property. It's particularly important that the solar panel receives as much sunlight as possible. Ensure that it is not obstructed by buildings, fences, trees, sheds, etc, or the shadows that these create. **If the solar panel is installed in a poor location, it may not perform to the best of its ability.**

To maximise the battery capacity, the lights should be charged in direct sunlight for at least 12-24 hours before being used for the first time.

The lights will turn ON/OFF automatically when left in the on position. Please note it is completely normal for the lights to come on at different times as it depends on how fast they charge in their location.

Assembly

1. Take the light and put down the bracket in a 90° position, perpendicular to the ground.
2. Using a regular household tool, ideally an open-end wrench, tighten the hexagon nuts clockwise.
3. Keep the solar panel in the dark, and then use the needle object provided to press the switch in the back cover of the light until the light turns on.
4. Adjust the solar panel left or right and up or down. (Attention: rotating one-way 360° to left or right cannot be done, but you can rotate 180° to left or right).
5. Finally, insert the spotlight in the lawn or soft ground.

Attention: The spike of the lamp is very sharp. Please pay attention to your safety and keep it out of reach of children.

How to use:

Mode 1: Light is set to remain at low brightness until motion is detected which activates high brightness for up to 15 seconds.

Mode 2: Light will only activate when motion is detected for up to 15 seconds [**This is the best mode for winter**].

Mode 3: Light is set to remain OFF.

Troubleshooting

Please ensure that there are no nearby light sources shining on the solar panel after dark. These could be bright indoor/outdoor lights from your property or neighbours, or streetlights.

If you are unsure, take the light inside and test it in a dark room.

If you are encountering any problems with your Salisbury Spotlight often you can resolve this yourself by following our troubleshooting guide. If the light has its solar panel in a poor location it will struggle to work, but that doesn't mean there is a fault with the unit. Please remember that the light will arrive with some charge and will likely work for a few days even if the solar panel is poorly located. Please try the troubleshooting tips below before contacting your retailer.

Recharge Procedure

1. Double check the location of your solar panel to ensure it is in a clear location and as South facing as possible.
2. Turn the light off at the switch and leave it to recharge for 3-5 days ensuring one sunny day has passed.
3. After 3-5 days return to the light and turn it back on at the switch.
4. If your light still does not illuminate after dark, please contact your retailer.

Maintenance

Clean the surface of the solar panel and light lens with a soft, slightly moistened cloth. Do not use corrosive cleansing agents or chemical solutions as these may damage surfaces and impair operation. Keep the solar panel free of dirt, debris and snow.

Safety Instructions

The Solar Centre assumes no liability for any damage resulting from the use of this product, nor do we assume liability for any damage to property or personal injury caused by improper use or failure to observe these instructions.

Unauthorised conversion and/or modification of the unit may be dangerous and will invalidate your warranty. To avoid damage to sight, do not look directly at the light source. This device is not a toy and should be kept out of reach of children. Do not submerge the device in water or expose it to extreme temperatures (less than -25°C or higher than 50°C).

For customer support please contact:

The Solar Centre Ltd

44-46 Coldharbour Lane

Harpenden

Hertfordshire

AL5 4UN

T: 01727 743200

W: solarcentre.co.uk

E: info@solarcentre.co.uk

